

DATASHEET

D:PLOY - PALLETIZING APPLICATION

v1.0.600

Palletizing Application

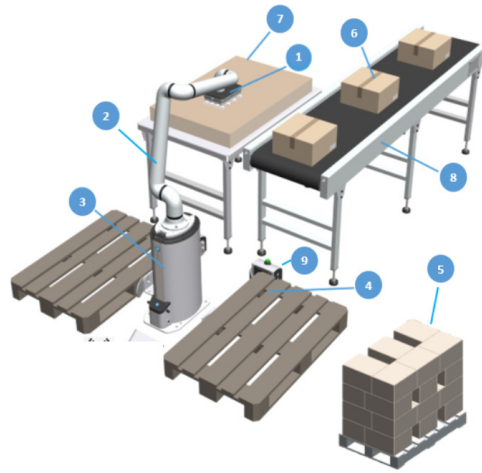

1/a.	Grippers	2FGP20		VG10		VGC10		VGP20			
1/b.	Tool mounting	Quick Changer		Extender Bracket		Angle Bracket 45°		Angle Bracket 90°			
2.	Robot brands	ABB	Denso	Doosan		Elite	FANUC	FANUC CRX			
		Techman		UR	Jaka	Omron TM	Kawasaki	Yaskawa			
3.	Robot mounting	Lift100 v2			Lift100 v1			Any fixed pedestal			
4.	Pallet sizes	EUR1/ISO1	EUR2/ISO2	EUR6/ISO0	UR1/ISO3	US2/ISO4	US3	ASIA/ISO5	UK	AUSTRALIAN	Custom
5.	Pattern options	Automatic (optionally interlocked and/or having the labels facing outward, compacted or stretched)				Manual (easy to use pattern editor, powerful suggestions, optionally have labels rotated outward, spacing within boxes or from edges for snapping)					
6.	Box size/weight/type	Any size (that the gripper can handle)			Any weight (that gripper and robot can handle)			Cardboard or KLT box			
7.	Interlayer sheet	Cardboard or Paper		Full or half size		Sheets can be picked from a fixed position (spring loaded tray) or based on thickness D:PLOY can "search" for the next one (normal tray)		Horizontal or tilted trays supported (recommended to place above the conveyor belt close to the infeed)			
8.	Infeed type/multiple boxes	Conveyor belt or Turn table				Single Box or Multiple Boxes (two box at once for faster cycle time - requires two sensors in a twin signal configuration)					

9. Pallet detection/positioning	Automatic Pallet Station (with Lift100 v2)	Pallet Station (Lift100 v1)	No Pallet Station (Fixed pedestal)
--	--	-----------------------------	------------------------------------

Additional Information

1/a. Grippers

Only OnRobot tools are supported, but can be customized with any OnRobot accessory, or custom fingertip/vacuum accessory.

Grippers			
2FGP20	VG10	VGC10	VGP20
✓	✓	✓	✓

1/b. Tool mounting

Dual Quick Changer and HEX-E/H QC are not supported.

2. Robot brands

Supported robot models and controllers

Robot Type	ABB	Denso	Doosan	FANUC	FANUC CRX
Robot Model	CRB 1100 -4/0.58 CRB 15000 -5/0.95 CRB 15000 -10/1.52 CRB 15000 -12/1.27 IRB 1100 -4/0.58 IRB 1100 -4/0.47 IRB 120 IRB 1200 -5/0.9 IRB 1200 -7/0.7 IRB 1300 -7/1.4 IRB 1300 -10/1.15 IRB 1300 -11/0.9 IRB 1300 -12/1.4 IRB 1600 -6/1.2 IRB 1600 -6/1.45 IRB 1600 -10/1.2 IRB 1600- 10/1.45	VM-6083 VM-60B1 VP-6242 VS050A3 VS087A4 VP-5243 VS-050-S2 VS-087A4 VS-6577 VS-6556 VS-087	A0509 A0509s A0912 A0912s H2017 H2515 M0609 M0617 M1013 M1509 E0509	CR-7iA CR-7iA/L CR-14iA/L CR-15iA CR-35iB LR Mate 200iD LR Mate 200iD/4S LR Mate 200iD/7L LR Mate 200iD/14L	CRX-5iA CRX-10iA CRX-10iA/L CRX-20iA/L CRX-25iA
Robot Controller	IRC5 OmniCore	RC8	CS-03 CS-04	R-30iB R-30iB Plus R-30iB Mini Plus	R-30iB Mini Plus

Robot Type	JAKA	Techman	UR	Omron TM	Kawasaki	Yaskawa	Elite
Robot Model	Zu3 Zu3S Zu5 Zu5S Zu7 Zu7S Zu12 Zu12S Zu18 Zu18S Pro5 Pro12 Pro16	TM5-700 TM5X-700 TM5-900 TM5X-900 TM5S TM5S-X TM7S TM7S-X TM12 TM12X TM12S TM12S-X TM14 TMX14 TM14S TM14S-X TM16 TM16X TM20 TM20X TM25S TM25S-X	UR3 UR3e UR5 UR5e UR10 UR10e UR16e UR20 UR30	TM5-700 TM5X-700 TM5-900 TM5X-900 TM5S TM5S-X TM7S TM7S-X TM12 TM12X TM12S TM12S-X TM14 TMX14 TM14S TM14S-X TM16 TM16X TM20 TM20X TM25S TM25S-X	RS003N RS005L RS005N RS006L RS007N RS007L RS010L RS010N RS013N RS015X RS020N RS025N RS030N RS050N RS080N	GP4, GP4FGG GP7, GP7FGG GP8, GP8FGG, GP8FGG HS GP8L GP12, GP12FGG GP20 GP20HL GP25, GP25FGG GP25-12 GP35L HC10 HC10DT HC10DTP, HC10DTPF, HC10DTP Classic HC20 HC20DT HC20DTP HC30PL	CS63 CS66 CS612 CS620 CS625
Robot Controller	Electrical cabinet	TM	CB3 e-Series CB5.3+	TM	E01 E02 F01 F02 F60	YRC1000 YRC1000 Micro	EliRobot + EliServer

3. Robot mounting

The robot cannot be tilted while using the Lift100. The Lift100 v2 can move upwards in parallel with the robot.

4. Pallet types and sizes

Up to two pallets of the same type is supported. Any custom pallet sizes can be added easily.

Pallet type	Size (L x W x H)	Unit
North America/US 1/ISO3	1016 x 1219 x 127 40 x 47.99 x 5	[mm] [inch]
North America/Drums/US 3	1219 x 1219 x 127 47.99 x 47.99 x 5	[mm] [inch]
Australia/US 2/ISO4	1165 x 1165 x 150 45.87 x 45.87 x 5.91	[mm] [inch]

Pallet type	Size (L x W x H)	Unit
EUR 1/ISO1	1200 x 800 x 144 47.24 x 31.50 x 5.67	[mm] [inch]
EUR 6/ISO0	600 x 800 x 144 23.62 x 31.51 x 5.67	[mm] [inch]
EUR 2/ISO2	1200 x 1000 x 145 47.24 x 39.37 x 5.71	[mm] [inch]
Asia/ISO5	1100 x 1100 x 135 43.31 x 43.31 x 5.31	[mm] [inch]
Custom	Min.: 600 x 800 Max.: 1250 x 1250	[mm]
	Min.: 23.62 x 31.50 Max.: 49.21 x 49.21	[inch]

5. Pattern options

All calculations are done in the cloud, using fast servers to save time for users.

6. Box type/size/weight



NOTE:

For KLT boxes to stack properly, the minimum tolerance needed is +/- 5 mm.

- Minimum box size: The recommended minimum box size is 200 x 200 x 100 mm (7.87 x 7.87 x 3.94 inches).
- Minimum box weight: The recommended minimum weight for the box is 0.5 kg (1.1 lb) for the default speed and acceleration.

7. Interlayer sheet

This is optional, and only shown if **Interlayer sheet sensor** device is configured in the cell setup. The sensor can be any ultrasonic, laser/infra or any other type 24V digital sensor.

Sheets can be picked from a fixed position (spring loaded tray) or based on thicknessú, D:PLOY can “search” for the next one (normal tray).

8. Infeed type/multiple boxes

Two boxes at once for faster cycle time - requires two sensors in a twin signal configuration during the cell setup.

With Multiple boxes, if the pattern has an odd number of boxes, D:PLOY automatically handles this (by changing back to Single Box when needed).

Integrator needs to take care of the conveyor belt driving and timing (based on the infeed sensor). The infeed sensor can be any ultrasonic, laser/infra or any other type 24V digital sensor.

9. Pallet detection/positioning

- **Automatic Pallet Station** (with Lift100 v2): no sensor setup is needed, position is prefilled - automatically added to the cell setup
- **Pallet Station** (with Lift100 v1): digital I/O sensor setup is needed, position is prefilled - **Pallet Station** device to be added to the cell setup
- **No Pallet Station** (in case of a fixed pedestal): digital I/O sensor setup is needed, position needs to be manually taught (3 corners) - **Pallet sensor** device to be added to the cell setup

In any case, the non-level floor (or any mounting issue) can be solved by switching to manual pallet position teaching (3 corners with a box). The **Pallet sensor** can be any ultrasonic, laser/infra or any other type 24V digital sensor.

Estimated cycle time

The displayed cycle time in D:PLOY is an estimate. The actual cycle time might vary, depending on the parameters of your application and your robot:

- For ABB, the error on the estimation is expected to be less than 5%.
- For Denso, the error on the estimation is expected to be less than 5%.
- For Doosan, the error on the estimation is expected to be less than 15%.
- For FANUC, the error on the estimation is expected to be less than 10%.
- For Techman, the error on the estimation is expected to be less than 10%.
- For UR, the error on the estimation is expected to be less than 5%.
- For Omron TM, the error on the estimation is expected to be less than 10%.
- For Kawasaki, the error on the estimation is expected to be less than 5%.
- For Yaskawa, the error on the estimation is expected to be less than 10%.

Layout configuration

- One or two pallets
- With or without interlayer sheet
- Single or multiple boxes being picked
- Infeed/Interlayer at any angle

Examples

